

# Matrix III EH

## EM-Marine / HID ProxCard II 125KHz RFID reader with connection via iButton (1-Wire) / Wiegand-26 protocols User Manual

### 1. GENERAL INFORMATION

**Matrix III EH Reader** is used in Access Control Systems (ACS). The reader transmits into the controller the codes of EM-Marine or HID ProxCard II tokens (cards or key fobs) presented to it, via iButton (Dallas Touch Memory) or Wiegand-26 protocols.

### 2. OPERATION

The reader operation without activating external indication control (i.e. staying under internal indication control):

1. In standby mode, the red LED shines solid.
2. On card approach, the red LED goes off and the green LED flashes once, and a short beep sounds.
3. While the card remains within working zone, no LED indication is provided.

The external indication control for the LEDs and the buzzer is initiated by connecting corresponding terminals to common ground. The external indication control for one mode can be used with internal indication control for another; if, for instance, external indication signal for LEDs is activated, the LEDs get under external control, while the buzzer remains under internal control.

### 3. MOUNTING AND CONNECTION

To mount the reader, perform the following sequence:

- Mark and drill the mounting holes per Fig. 2;
- Connect the reader wires according to Table 1;
- Insulate all wire junction points;
- Power up the device (the red LED will come on);
- Test the reader operation by touching it with a token;
- Mount the reader in its desired place and fix it with screws;
- Install the decorative cover and fix it with a screw.

Note 1: Leave 10 cm or more between any two readers.

Note 2: To achieve the specified distance from controller, a UTP cable (e.g. CAT5e compatible) must be used as follows:

- When using iButton protocol, one wire from the twisted-pair should be connected to GND and another to DATA0 terminal.
- When using Wiegand 26 protocol, the first twisted pair is connected between GND and DATA0, and the second one between GND and DATA1, as per Fig. 1.

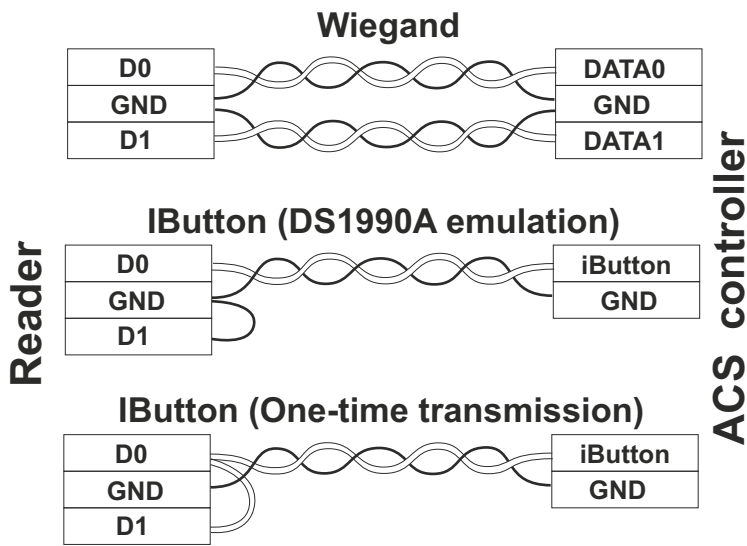

Figure 1. Choosing the transmission protocol.

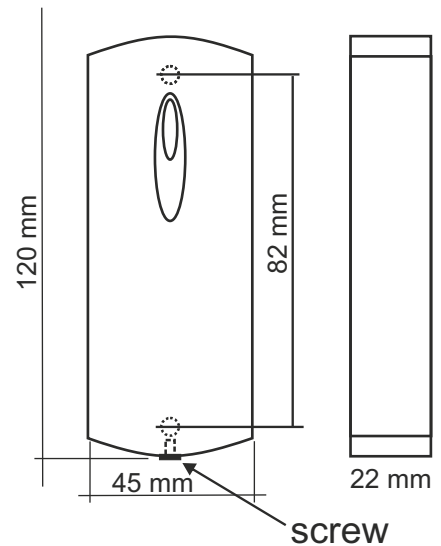

Figure 2. Device Dimensions.

Table 1. Controller connections.

Wire Colour	Wire Designation
Red	+12V
Black	Common (-)
White	DATA0
Brown	DATA1
Green	External control for the green LED
Yellow	External control for the red LED
Blue	External control for the buzzer

4. SPECIFICATIONS

- Working frequency: .....125 kHz;
- Used token types: .....EM-Marine, HID ProxCard II;
- Reading distance: .....2...10 cm;
- Output interface: .....Wiegand-26, iButton (Dallas Touch Memory);
- Line distance via iButton protocol: .....up to 15 m;
- Line distance via Wiegand-26 protocol: .....up to 100 m;
- Power supply voltage: .....12 V DC;
- Power supply current: .....max. 35 mA;
- Status indication: .....visual LED, audial buzzer;
- External status indication control: .....for audial and visual indication;
- Case material: .....ABS plastic;
- Dimensions: .....120 × 45 × 22 mm.

## 5. OPERATING CONDITIONS

Ambient temperature: -30...40°C.

Humidity: ≤98% at 25°C.

When operating under non-recommended conditions, device parameters can deviate from specified values.

## 6. PACKAGE CONTENTS

- **MATRIX III EH** Reader: ...1
- Screw: .....1
- Screws 3.5×40: .....2
- Wall Plugs: .....2

## 7. LIMITED WARRANTY.

This Device is covered by limited warranty for 24 months.

The warranty becomes void, if:

- this Manual's guidelines are not followed;
- the device has suffered physical damage;
- the device has visible traces of exposure to moist and/or aggressive chemicals;
- the device circuits have visible traces of tampering by unauthorised parties.

Under this warranty, the Manufacturer shall repair the device or replace any broken parts as required, free of charge, in cases where the fault is caused by a Manufacturer's defect.

## 8. IRONLOGIC CONTACTS

### Headquarters:

RF Enabled ID Limited  
34 Ely Place, London, EC1N 6TD, UK  
E-mail: [marketing@rfenabled.com](mailto:marketing@rfenabled.com)

### Development and production:

AVS LLC  
7, Bobruiskaya street, Saint-Petersburg, 195009, Russian Federation  
E-mail: [marketing@rfenabled.com](mailto:marketing@rfenabled.com)  
Phone: +78122411853; +78125421185  
[www.ironlogic.ru](http://www.ironlogic.ru)

### Authorized representative in the European Union:

SIA IRONLOGIC  
79A, Slokas iela, LV-1007, Riga, Latvia  
E-mail: [info@ironlogic.lv](mailto:info@ironlogic.lv), [headstaff@ironlogic.lv](mailto:headstaff@ironlogic.lv)  
Phone: +37166181894; +37124422922  
[www.ironlogic.me](http://www.ironlogic.me)



The symbol of crossed-through waste bin on wheels means that the product must be disposed of at a separate collection point. This also applies to the product and all accessories marked with this symbol. Products labeled as such must not be disposed of with normal household waste, but should be taken to a collection point for recycling electrical and electronic equipment. Recycling helps to reduce the consumption of raw materials, thus protecting the environment.

