

# CP-Z

## ACS RFID EM-Marine reader (125 kHz)

### User Manual

#### 1. OVERVIEW

CP-Z RFID reader is used in Access Control Systems (ACS) to transmit into controllers the code of presented EM-Marine contactless tokens (card, key fob, etc.) via iButton protocol. The reader supports concealed installation both indoors and outdoors. Device specifications and casing design assure the device operation even through a layer of plaster or plasterboard.

#### 2. MOUNTING AND CONNECTION

The reader should be mounted on a flat surface in a location allowing easy approaching by the tokens.

To mount the reader, please perform the following steps:

- Unscrew and remove the top lid;
  - Mark and drill mounting holes of the same size as the mounting holes in reader casing (Figure 2);
  - Fix the casing lid without PCB at the correct reader installing place;
  - Connect the wires to reader socket per connection scheme (Figure 1);
- Close the reader casing lid and screw it in desired place.

#### Notes:

1. When powered on, the reader buzzer emits one beep.
  2. Device supports concealed installation, either behind dielectric surfaces up to 1 cm thick, or enclosed into a wall. However, the reading distance in this case is reduced, so please check the reading quality before finishing the mounting.
  3. Do not install readers within 10 cm from each other! Also, when the distance between two readers is less than 30 cm, their working zone may be reduced.
- To operate at the top of the specified line distance to controller, please use a UTP cable CAT5e. One wire of the twisted pair should be connected to GND, another to D0. (See Figure 3).

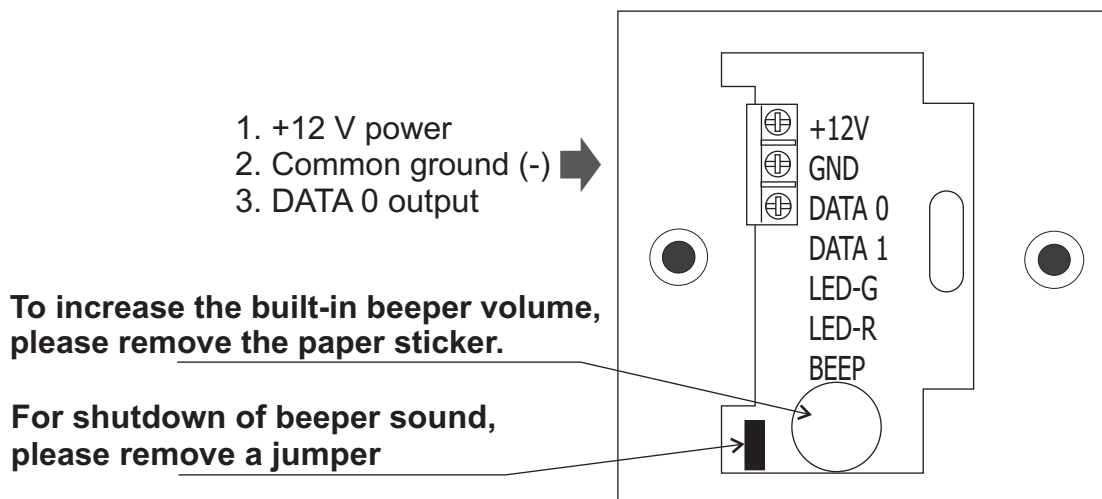

*Figure 1. Connection layout.*

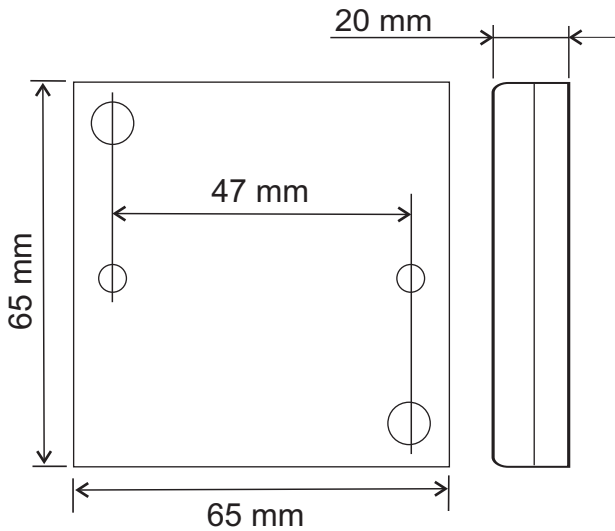

**Figure 2.** Device dimensions.



**Figure 3.** Connecting reader via UTP cable CAT5e.

### 3. READER OPERATION

When a token is brought into reader working zone, its serial number is acquired. It is then transmitted into controller using iButton (Dallas Touch Memory) protocol.

When reading the token serial number, the buzzer is sounding. To disable the buzzer, remove the jumper on the reader PCB. (See Figure 1)

### 4. SPECIFICATIONS

Working frequency: .....	125 kHz.
Supported token type: .....	EM-Marine.
Reading distance: .....	2...8 cm.
Output protocol: .....	iButton.
Max. line distance from the controller: .....	15 m.
Reading indication: .....	audial buzzer.
Quiet reading function: .....	Present.
Power voltage: .....	12 V DC.
Maximum standby current: .....	30 mA.
Casing material: .....	ABS plastic.
Dimensions, mm: .....	65 x 65 x 20.
Weight: .....	40 g.

### 5. OPERATIONAL CONDITIONS

Recommended air temperature: -30...40°C.

Humidity: ≤ 80% at 25°C.

If operational conditions are differing from described above, device specifications can deviate from specified values.

The controller is to be operated in absence of: precipitation, direct sunlight, sand, dust, water condensation.

## 6. PACKAGE CONTENTS.

- CP-Z RFID Reader .....1
- Jumper.....1

## 7. LIMITED WARRANTY

This device is covered by a limited warranty for 24 months from the date of sale.

The warranty becomes void if:

- This Manual is not followed;
- Device has physical damage;
- Device has visible traces of exposure to moisture and aggressive chemicals;
- Device circuits have visible traces of being tampered with by unauthorised parties.

Under active warranty, the Manufacturer will repair the device or replace any broken parts, FREE of charge, if the fault is caused by manufacturing defect.

## 8. IRONLOGIC CONTACTS

### Headquarters:

RF Enabled ID Limited  
34 Ely Place, London, EC1N 6TD, UK  
E-mail: [marketing@rfenabled.com](mailto:marketing@rfenabled.com)

### Development and production:

AVS LLC  
7, Bobruiskaya street, Saint-Petersburg, 195009, Russian Federation  
E-mail: [marketing@rfenabled.com](mailto:marketing@rfenabled.com)  
Phone: +78122411853; +78125421185  
[www.ironlogic.ru](http://www.ironlogic.ru)

### Authorized representative in the European Union:

SIA IRONLOGIC  
79A, Slokas iela, LV-1007, Riga, Latvia  
E-mail: [info@ironlogic.lv](mailto:info@ironlogic.lv), [headstaff@ironlogic.lv](mailto:headstaff@ironlogic.lv)  
Phone: +37166181894; +37124422922  
[www.ironlogic.me](http://www.ironlogic.me)



The symbol of crossed-through waste bin on wheels means that the product must be disposed of at a separate collection point. This also applies to the product and all accessories marked with this symbol. Products labeled as such must not be disposed of with normal household waste, but should be taken to a collection point for recycling electrical and electronic equipment. Recycling helps to reduce the consumption of raw materials, thus protecting the environment.

