

Z-396 EHT RFID Electronic Furniture Lock with EM-Marine & HID ProxCard II & Atmel (T5557) reader (125 kHz) and standalone controller User Manual

1. OVERVIEW

Z-396 EHT electronic lock is a contactless reader combined with a standalone controller and electromechanical lock. The lock is powered by four AA type batteries. Compact, with five operational modes, easy in installation, programming and servicing, this lock is a perfect access control solution for various storage places: gym lockers, changing cabins, office furniture, trade equipment. Particularly broad application of these locks happens in places like SPA, water parks, gyms, swimming pools.

A **Z-396 EHT** lock can be installed as a standalone device, or as a part of a complex access control solution. For access keys, it accepts contactless key fobs and bracelets. Z-396 EHT can operate in five different modes:

- **Gym Mode:** keys are not tied to locks. Any key can open and close any free locker.
- **Logic Mode:** keys are not tied to locks. Any key can open and close any free locker. The number of used locker and battery levels are stored into keys. This is convenient when the user forgets which locker he used. Can set the maximum for the number of lockers per one user (range 1 to 15). Computerized logging and lock setup. Only works with Lock Manager software.
- **General Mode:** a typical lock controller operation: only the key(s) stored in the lock's memory (maximum 24) can open that lock.
- **Safe Deposit Box Mode:** the lock emulates safe deposit box operation. To open the lock, all the keys in controller database (max. 26) must be swiped to it, one after another.
- **Custom Mode:** you can design your own custom operational logic, subject to your needs. Then obtain updated firmware from the Manufacturer and download it into the lock with an **RF-1996** adapter.

Programming of operational modes, Master and User cards, is done via Reset button on the lock's case (see Chapters 4 to 11) or via **Lock Manager** software using an **RF-1996** adapter (see Chapter 12). Selected modes and cards database are stored in the lock's NVRAM (non-volatile memory).

After one of the modes selected and all configuration done, the lock starts to work according to these rules:

On key swipe to the lock's reader,

- if the token has access granted, a beep sounds and the LED flashes green, or else
- if the token has access denied, a beep sounds and the LED flashes red.

Z-396 EHT Electronic Lock Operational Modes Comparison Table.

Features	Operational Modes				
	Gym	Logic*	General	Safe Deposit Box	Custom
Any key can open/close any locker	+	+			+
Limit on lockers number that can be taken by one bracelet. The operator defines the maximum lockers number for one bracelet (1...15)		+			+
Logging of free/taken lockers currently		+			+
Logging the gym attendance times		+			+
Information Kiosk (tells the client their locker number,if forgotten)		+			+
Battery charge level recorded into bracelet		+			+
Encryption, protection against bracelet cloning		+			+
Locks setup and further use without a PC	+		+	+	+

* Note:**Logic Mode** requires special Atmel (T5557) keys and **Lock Manager** software.

2. SPECIFICATIONS

- Working Frequency: 125 kHz;
- Keys standards:EM-Marine, HID ProxCard II, Atmel (T5557);
- Maximum number of keys:Normal - 26; Master - 4;
- NVRAM to store settings:Present;
- Reading distance:2...4 cm;
- Standby consumption current:30 μ A;
- Audio-visual status indication:buzzer, bicoloured LED;
- Working temperature range:+5...+40 °C;
- Case material:metal, ABS plastic;
- Dimensions, mm:
 - External module72x43x21;
 - Internal module145x64x22;

3. MOUNTING

To mount the lock, you will require:

1. Drill;
2. \varnothing 25mm spade drill bit (to mount onto wooden furniture);
3. Drill bit (to mount onto metal furniture);
4. Phillips screwdriver;
5. Hex 2.5 mm socket wrench;

Installation onto a wooden (chipboard) locker

1

Make a 25 mm hole in the locker's door. To mark the hole position use template from Fig. 13.

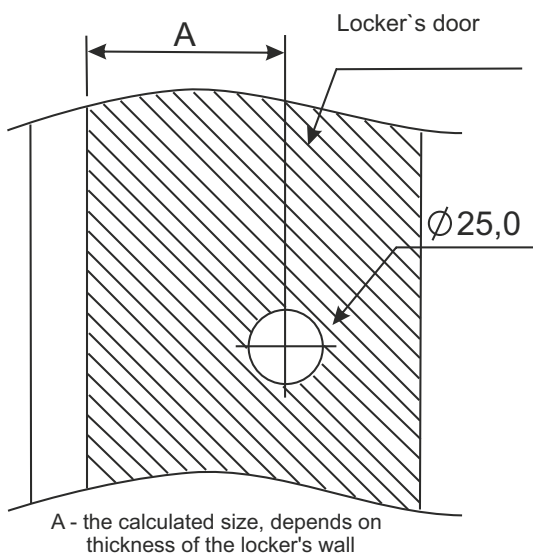

Fig.1

2

Connect cable to lock's PCB.

Note: Check that cable socket is firmly connected with lock's PCB socket. Install the locking module according to Fig. 2.

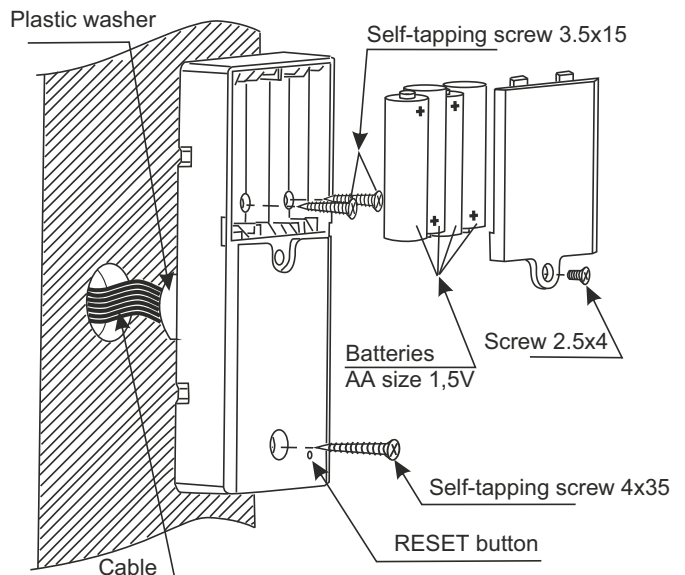

Fig.2

3

Connect cable to the reader's module.

Note: Check that cable socket is firmly connected with readers's module socket. Install the reader's module according to Fig. 3.

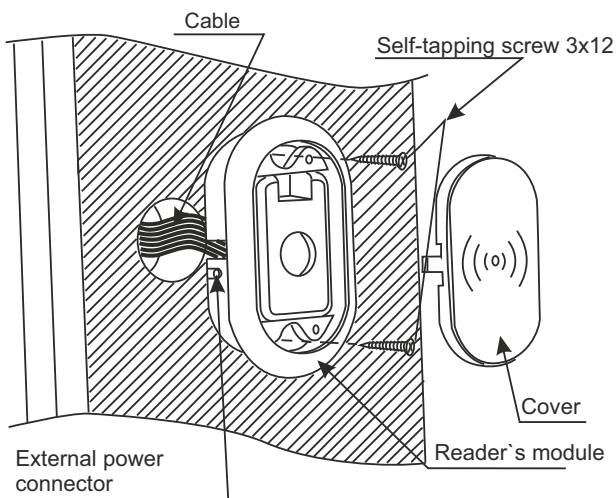

Fig.3

4

Install push bolt unit onto the locker's wall (See Fig.4,5)
To mark the hole position use template from Fig.13

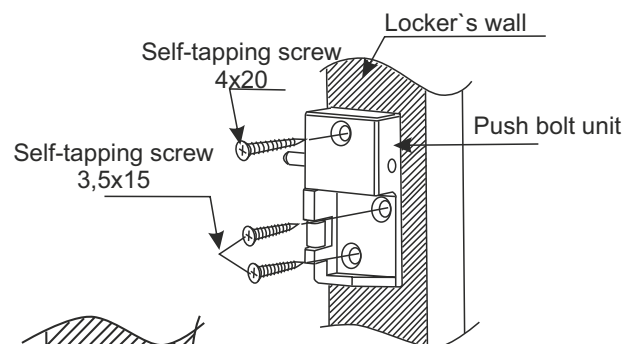

Fig.4

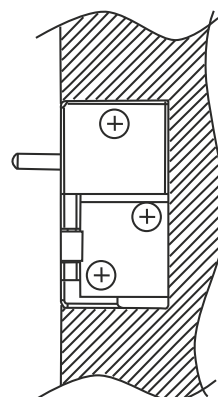

Fig.5

Installation onto a metal locker

Due to the particular design of the metal lockers, the NAK-1 spacers kit may be required. The Z-396 EHT mounting with their use is shown below.

- 1** Make holes in the locker's door. To mark the hole position use template from Fig. 14.

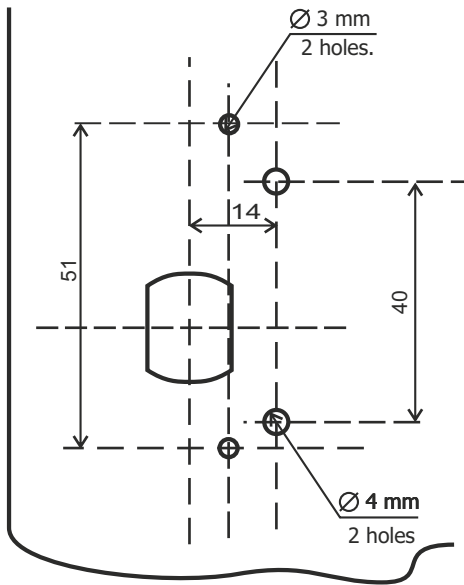

Fig.6

- 2** Mount the NAK-1 spacer from the inside of the locker's door. Connect cable to lock's PCB.
Note: Check that cable socket is firmly connected with lock's PCB socket. Install the locking module according to Fig. 7

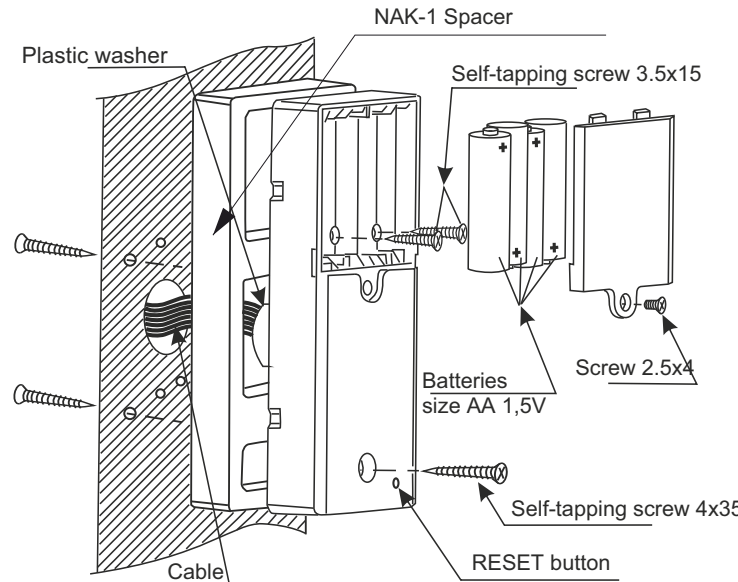

Fig.7

- 3** Connect cable to the reader's module.
Note: Check that cable socket is firmly connected with readers' module socket. Install the reader's module according to Fig. 8.

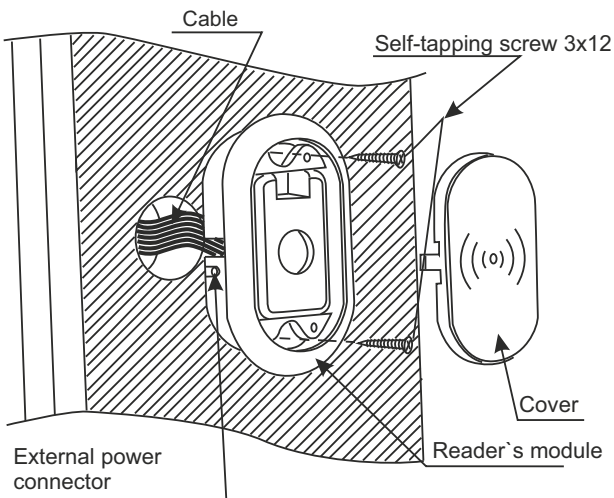

Fig.8

- 4** Install push bolt unit onto the locker's wall (See Fig.9)
 To mark the hole position use template from Fig.14

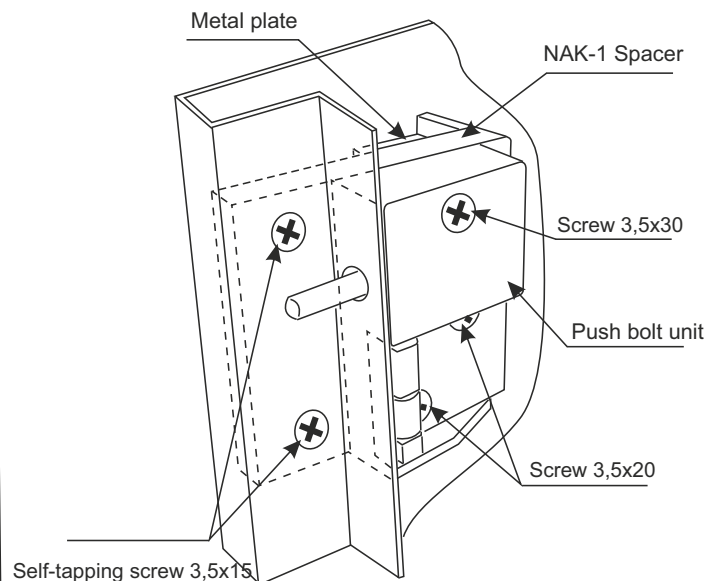
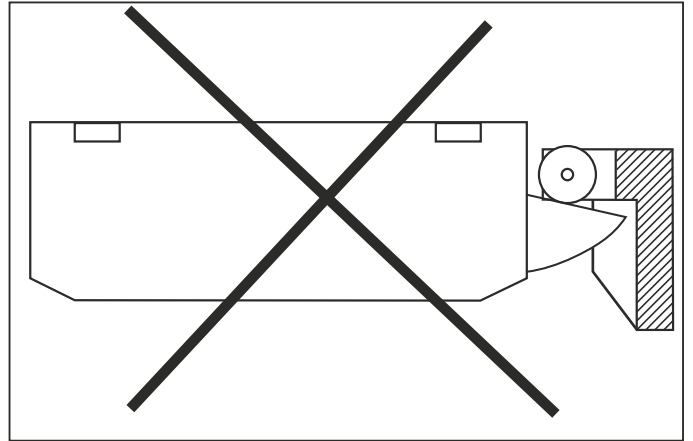
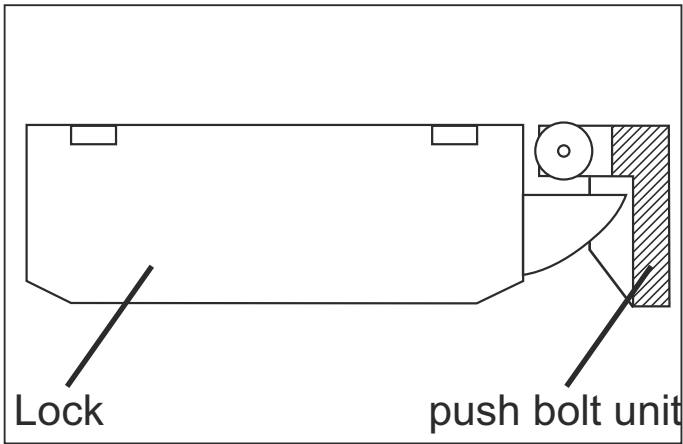

Fig.9

How to install the Z-396 EHT lock properly

Top view



View from inside the door

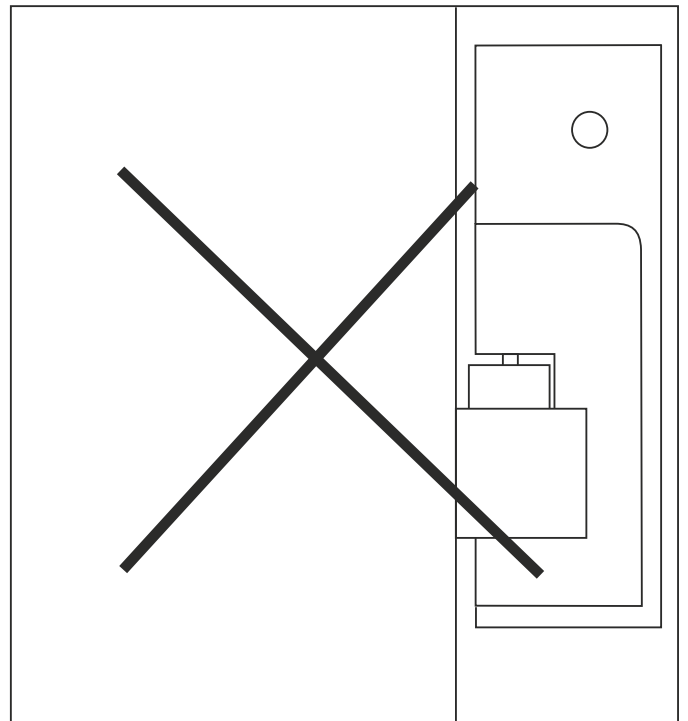
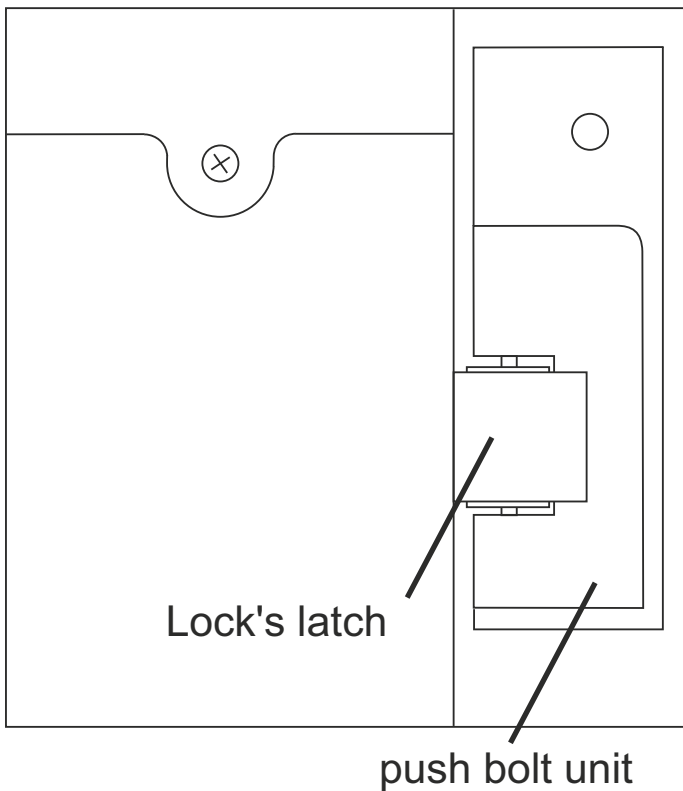

4. INITIAL POWER-UP, ADDING MASTER KEYS BY RESET BUTTON

Initial power-up sequence (No keys in lock's memory)

- Connect the reader module to the lock module by a supplied cable.
- Insert four AA batteries.
- Swipe the reader by any EM-Marine key.
- The controller issues audible and visual signals.
- Device is ready for operation.

Note: For consistent reader operation, keys with label diameter 15...35 mm are recommended.

To add a Master key, perform the following steps:

- Disconnect the power (take out one of the batteries or use the external power supply switch, per Fig. 10);
- Push and hold the RESET button with a sharp tool (hairpin, toothpick, straightened paper clip etc.)
- Connect the power (re-insert the battery, or use the external power supply switch again, per Fig. 10), and only after that release the RESET button;
- Within 5 s after this, push and hold RESET button again;
- Swipe up to 4 keys to promote to Master one by one still holding RESET down;
- Release RESET button. In 6 s, both audible and visual signals will confirm exit from the Add Master Key mode.

5. SELECTING AND SETTING OPERATIONAL MODE BY RESET BUTTON

Note: Cannot select operational mode without a Master key.

The lock supports four pre-customised operational modes:

- **Gym mode:** allows not to tie up the key to the lock. The user chooses which of the available lockers to use.
- **Logic mode:** allows recording the used locker number and battery level into the key (bracelet). Very convenient when the user forgets which locker he used. Allows not to tie up the key to the lock. The user will decide which of the free lockers to use. Works only with Lock Manager software.
- **General mode:** traditional lock controller operation: only the keys recorded in lock's database can open the locker;
- **Safe Deposit Box mode:** safe deposit box mode emulation. To open the lock, all the keys in lock's database need to be presented to the lock, one after another.

In addition to the above modes you can order your own **Custom mode**, which will be designed according to your needs.

At factory settings, **Gym mode** is pre-selected by default. It is activated straight after the Master key(s) have been added. To select a different operational mode, follow these steps:

- Disconnect the power (take out one of the batteries or use the external power supply switch, as per Fig. 10);
- Press and hold the RESET button with a sharp tool.
- Connect the power (reinsert the battery, or use the external power supply switch, as per Fig. 10), and only after that release the RESET button;
- Press the RESET button shortly (once). The lock issues audible and visual signals *twice*. The lock is now in Logic Mode;
- Press the RESET button shortly (once). The lock issues audible and visual signals *three times*. The lock is now in General Mode;
- Press the RESET button shortly (once). The lock issues audible and visual signals *four times*. The lock is now in Safe Deposit Box Mode.
- Press the RESET button shortly (once). The lock issues audible and visual signals *once*. The lock is now in Gym Mode again.
- To confirm the selected mode, do nothing for 6 s. After 6 s, audible and visual signals acknowledge the exit from the Operational Mode selection.

6. GYM MODE

Note: Cannot select an operational mode without a Master key.

Rules of operations for Gym mode:

1. Opening the lock is possible with the key recorded when door was locked.
2. Locking is only possible when the lock is open (latch hidden within the lock);
3. Swipe the key to the reader. If it is valid, the lock is now armed (latch pops out, beep sounds and the LED flashes green);
4. After the lock is armed, the user can put his possessions inside and close the door.
5. While the lock is armed (door is closed), the LED flashes red, showing that this locker is occupied.
6. If a key not recorded in memory is swiped to the reader, a beep sounds and the LED flashes red.
7. If a correct key is swiped to the reader, a beep sounds and the LED flashes green. The key is erased from lock's memory, the latch is withdrawn inside the lock. The door is now open, lock is ready to restart the cycle from the beginning.

Action	Sound	LED	Latch	What for
Default state	None	None	OUT if a Normal key is in memory, Otherwise IN	Waiting for Normal key assignment
Swipe a key	●	G	OUT	Storing the key into the controller ("armed"), lock can be closed
Swipe another key	●●●	R blink	IN	Indicates wrong key
Swipe the recorded key	●	G	IN	Erasing key from controller, lock is waiting for Normal key assignment
Master key override, KEEPING the Normal key in the database				
Door closed, swipe Master key	●●●	R blink	IN	Master key override: opening the locker
Within 10 s, swipe Master key 2 nd time	●●●	R blink	OUT	Master key override: closing back the locker, Normal key still stored in database
Master key override, ERASING the Normal key from the database				
Door closed, swipe Master key	●●●	R blink	IN	Master key override: opening the locker
Wait 10 s, do nothing	●●●	R blink	IN	Master key override: erasing Normal key from database. Standby for a Normal key assignment.

Legend:

- - beep once, ●●● - multiple beeps, G - Green LED, R - Red LED, "blink" - blinking.

7. LOGIC MODE

Note: Cannot select an operational mode without a Master key.

Logic mode can only work with **Lock Manager** software and **Z-2 USB RF-1996** adapter.

Logic mode can also only work with **Atmel (T5557)** keys.

Additional Information about **Logic mode** operation can be found on the ironlogic.me website.

Rules of operations for **Logic mode**:

1. Opening the lock is possible with the key recorded when door was locked.
2. Arming the lock is only possible if the lock is currently open (the latch is INSIDE the lock);
3. Swipe the key to the reader. If it's valid, the lock becomes armed (latch pops OUT, beep sounds and the LED flashes green).
4. While arming the lock, it records the locker number and batteries charge level into the key.
5. After the lock is armed, the user can put his possessions inside the locker and close the door.
6. While the lock is armed (door is closed), the LED flashes red, showing that the locker is occupied.
7. Swipe the correct key to lock's reader, then a beep will sound, green LED will flash, the key will be erased from the lock's memory, the latch will be draw inside the lock. The door is now open, lock is ready to restart the cycle from the beginning.

Action	Sound	LED	Latch	What for
Default state	None	None	OUT if a locker is occupied, otherwise IN	Waiting for Normal key assignment
Swipe a key	●	G	OUT	Locker number and battery charge gets stored into the key, the lock can be closed
Swipe another key	●●●	G blink	IN	Indicates wrong key
Swipe the recorded key	●	G	IN	Opening the lock, the locker number and battery charge gets stored into the key.
Master key override, KEEPING the Normal key in the database				
Door closed, swipe Master key	●●●	R blink	IN	Master key override: opening the locker
Within 10 s, swipe Master key 2 nd time	●●●	R blink	OUT	Master key override: closing back the locker, Normal key still stored in database
Master key override, ERASING the Normal key from the database				
Door closed, swipe Master key	●●●	R blink	IN	Master key override: opening the locker
Wait 10 s, do nothing	●●●	R blink	IN	Normal key erased from database. Standby for next Normal key assignment.

Legend:

● - beep once, ●●● - multiple beeps, G - Green LED, R - Red LED, "blink" - blinking.

8. GENERAL MODE

Note: Cannot select an operational mode without a Master key.

Rules of operations for **General mode**.

1. Opening the lock is possible by the key recorded in lock's memory.
2. On 1st key swipe to lock's reader, the latch comes OUT, a beep sounds and the LED flashes green, the user can now put their possessions inside and close the door.
3. On 2nd key swipe to lock's reader, the latch gets drawn IN, a beep sounds and the LED flashes green, now the door is open again.
4. If a key not present in lock's memory is swiped, a beep sounds and the LED flashes red.

Action	Sound	LED	Latch	What for
Add Normal Keys				
Default state	None	None	IN or OUT	Waiting for Normal key to be stored
Swipe Master key 1 st time	●●●	R blink	IN	Entering Edit Normal Keys mode
Swipe Master key 2 nd time	●●●	R blink	OUT	Entering Edit Normal Keys mode
Swipe Master key 3 rd time for 6 s	●	R	IN	Entering Edit Normal Keys mode
Swipe 1 st , 2 nd , 3 rd , ..., Max (26 th) keys	●	G	IN	Recording Normal Key into the controller
Swipe Master key	●●●	R blink	OUT	Exiting Add Normal Keys mode
After 5 s	●●●	R blink	OUT	
Erase All Normal Keys				
Default state	None	None	OUT	Waiting for Normal key written
Swipe Master key 1 st time	●●●	R blink	IN	Entering Edit Normal Keys mode
Swipe Master key 2 nd time	●●●	R blink	OUT	Entering Edit Normal Keys mode
Swipe Master key 3 rd time for 6 s	●	R	IN	Entering Edit Normal Keys mode
Press button once	●	R	OUT	Erase All Normal keys
Swipe Master key	●●●	R blink	OUT	Exiting Erase All Normal Keys mode
After 5 s	●●●	R blink	OUT	
Master key override				
The door is closed. Swipe Master key	●●●	R blink	IN	Master key override, locker opening
Wait 5 s	●●●	R blink	OUT	Default state

9. SAFE DEPOSIT BOX MODE

Note: Cannot select an operational mode without a Master key.

Rules of operations for **Safe Deposit Box mode**.

1. The latch is always released (OUT), if the database is not empty;
2. Opening the lock is possible by swiping ALL the keys to the reader, one after another.
3. After all keys have been presented, a beep sounds and the LED flashes green, the lock's latch is withdrawn for 3 s and then is popped back out. If the door was locked, it's opened by a lock's push unit bolt.
4. If a key not present in memory is swiped, a beep sounds and the LED flashes red.

Action	Sound	LED	Latch	What for
Add Normal Keys				
Default state	None	None	OUT	Waiting for Normal key recording
Swipe Master key 1 st time	●●●	R blink	IN	Entering Edit Normal Keys mode
Swipe Master key 2 nd time	●●●	R blink	OUT	Entering Edit Normal Keys mode
Swipe Master key 3 rd time for 6 s	●	R	IN	Entering Edit Normal Keys mode
Swipe 1 st , 2 nd , 3 rd , ..., Max (24 th) keys	●	G	IN	Storing Normal Key into the controller
Swipe Master key	●●●	R blink	OUT	Exiting Add Normal Keys mode
After 10 s	●●●	R blink	OUT	
Erase All Normal Keys				
Default state	None	None	OUT	Waiting for Normal key written
Swipe Master key 1 st time	●●●	R blink	IN	Entering Edit Normal Keys mode
Swipe Master key 2 nd time	●●●	R blink	OUT	Entering Edit Normal Keys mode
Swipe Master key 3 rd time for 6 s	●	R	IN	Entering Edit Normal Keys mode
Press button once	●	R	OUT	Erase All Normal keys
Swipe Master key	●●●	R blink	OUT	Exiting Erase All Normal Keys mode
After 10 s	●●●	R blink	OUT	
Master key override				
The door closed, swipe Master key	●●●	R blink	IN	Master key override, locker opening
Wait 10 s	●●●	R blink	OUT	Default state

10. ERASING OF ALL MASTER KEYS

This function erases all Master keys from lock's database, leaving only the Normal keys intact. Also cancels the currently selected operating mode.

To erase all Master keys, please perform the following steps:

- a. Disconnect the power (remove one battery or use the switch on external power source, see Fig. 10);
- b. Push and hold the RESET button using any sharp tool;
- c. Connect the power (re-insert the battery or use the switch on external power source, see Fig. 10); continue to hold down the RESET button for 6 s until the beep and visual signal that will acknowledge that all Master keys have now been erased.
- d. After all Master keys have been erased, please record at least one Master key into lock's memory, so that an operational mode can be selected.

Note: Cannot choose an operational mode without a Master key!

11. RESET TO FACTORY DEFAULTS

This function resets the lock into initial (factory) state. All Master and Normal keys are erased, the currently selected operational mode is cancelled.

To reset to factory defaults, please perform the following steps:

- a. Disconnect the power (remove one battery or use the switch on external power source, see Fig. 10);
- b. Push and hold the RESET button using any sharp tool;
- c. Connect the power (re-insert the battery or use the switch on external power source, see Fig. 10); continue to hold down the RESET button for 16 s. The beep and visual signal will appear at 6 s and 16 s from the moment the RESET button was pressed down. The beep and visual signal at 16 s will confirm that the device is now reset to factory defaults.

12. PROGRAMMING USING Z-2 USB RF-1996 ADAPTER AND LOCK'S MANAGER SOFTWARE

Lock's Manager software along with **Z-2 USB RF-1996** adapter takes care about configuration, set up and further operations of electronic furniture locks.

Lock's Manager software comprises two modules:

- **Edit Module:** free module that configures and sets up electronic furniture locks and keys for further operations.
- **Manager Module:** module that takes care about day-to-day site operation. Manages keys and records attendance, monitors staff operations, provides periodic reports, monitors the used lockers numbers, provides the user info-kiosk function (will remind the user the locker number in case they forgot), controls the battery levels in the locks, protects against fraudulent card cloning. Works only in Logic Mode and with Atmel (T5557) keys.

Programming works as follows:

- **Install Edit Module** onto a laptop (required, so it can be taken to every lock on site for programming).
- Connect an **Z-2 USB RF-1996** adapter to the laptop.
- Select operational mode
- Record a Master card.
- Swipe the **Z-2 USB RF-1996** adapter to the lock's reader, to record the selected operational mode and Master card into that lock via contactless technology. The transmission takes 2...3 s after the laptop has been connected to the lock.

Detailed instructions for **Lock's Manager** software and **Z-2 USB RF-1996** adapter can be found on the ironlogic.me website.

13. BATTERY DISCHARGE INDICATION AND REPLACEMENT

With 1,500 mAh alkaline batteries, the lock is guaranteed to open at least 10,000 times, or to work 2.5 years in stand-by mode.

The lock controls the battery charge and informs the users that batteries need to be replaced.

- *Batteries need replacing.*

If on Normal key swipe, the LED is not flashing, but the lock is still working it means that lock's batteries are almost totally discharged and need replacing. If the batteries could not be timely replaced and the lock lacks energy to open the locker, please use external power module (power the lock via the connector present on the reader) and swipe the lock with the key (see Fig. 10)

- *Batteries are fully discharged.*

If on Normal key swipe, the LED is not flashing AND the lock's latch doesn't pop out it means that lock's batteries are fully discharged.

In Logic mode, the lock records the current battery charge level into the token, on each lock opening.

- *Batteries replacement.*

The lock's electronics include NVRAM for lock settings and keys, so they are not lost after batteries replacement. To replace the lock's batteries, please see Fig. 11.

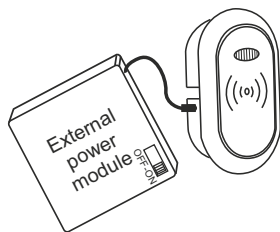

Fig.10

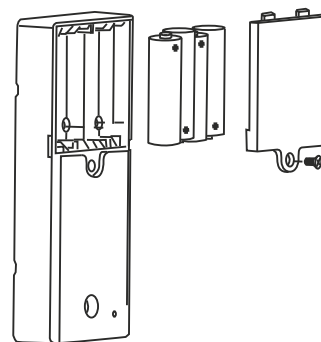

Fig.11

14. EMERGENCY OPENING

The lock possesses an emergency opening without need to use of contactless tags.

To open a lock without a tag, follow the following steps (see Figure 12):

- remove the cover;
- unscrew the screws;
- remove the reader's housing;
- slide the tab of the lock tongue to the right (you will need a thin screwdriver).

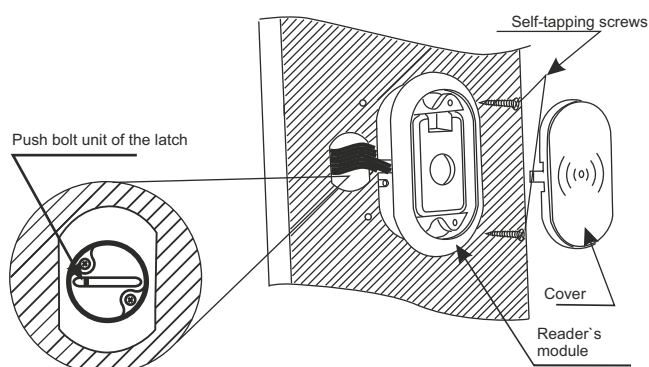

15. ADDITIONAL ACCESSORIES

Detailed information about all additional accessories can be found on the ironlogic.me website.

- **Metallic lock cover NAM-2**

Snaps onto the internal part of the lock. Provides attractive appearance and anti-vandal protection.

- **Set of spacers NAK-1**

This set is intended for installation of locks on the metallic lockers. It takes into account the profile design features of the metallic lockers.

- **External power module**

Provides power for locks. Convenient when programming the locks' operational mode. Used to provide power to the lock, if the batteries are completely discharged and the lock is closed.

- **Bracelets (identifiers)**

- **Lock module for lockers**

A spare lock module without electronics, for replacement or repairs.

- **Z-2 USB RF-1996 adapter**

Used to set up the locks from the portable computer and subsequent bracelets programming.

- **LOCK'S MANAGER software**

Used to set up the locks from the portable computer and subsequent bracelets programming.

16. OPERATING CONDITIONS

Ambient temperature: +5...+40°C.

Humidity: ≤ 98% at 25°C.

When operating under non-recommended conditions, device parameters can deviate from specified values.

17. LIMITED WARRANTY.

This Device is covered by limited warranty for 24 months since the purchase date.

The warranty becomes void, if:

- this Manual's guidelines are not followed;
- the device has suffered physical damage;
- the device has visible traces of exposure to moist and/or aggressive chemicals;
- the device circuits have visible traces of tampering by unauthorised parties.

Under this warranty, the Manufacturer shall repair the device or replace any broken parts as required, free of charge, in cases where the fault is caused by a Manufacturer's defect.

18. PACKAGE CONTENTS

- Lock module: 1;
- Reader module: 1;
- Battery compartment cover: 1;
- Decorative cover for the reader..... 1;
- Cable with connectors: 1;
- Push bolt unit: 1;
- Fixing set: 1;
- Plastic washer..... 1;

19. IRONLOGIC CONTACTS

Headquarters:

RF Enabled ID Limited
34 Ely Place, London, EC1N 6TD, UK
E-mail: marketing@rfenabled.com

Development and production:

AVS LLC
7, Bobruiskaya street, Saint-Petersburg, 195009, Russian Federation
E-mail: marketing@rfenabled.com
Phone: +78122411853; +78125421185
www.ironlogic.ru

Authorized representative in the European Union:

SIA IRONLOGIC
79A, Slokas iela, LV-1007, Riga, Latvia
E-mail: info@ironlogic.lv, headstaff@ironlogic.lv
Phone: +37166181894; +37124422922
www.ironlogic.me



The symbol of crossed-through waste bin on wheels means that the product must be disposed of at a separate collection point. This also applies to the product and all accessories marked with this symbol. Products labeled as such must not be disposed of with normal household waste, but should be taken to a collection point for recycling electrical and electronic equipment. Recycling helps to reduce the consumption of raw materials, thus protecting the environment.



Holes Layout for Z-396 EHT installation onto a wooden (chipboard) locker, with door's thickness in 16 mm.

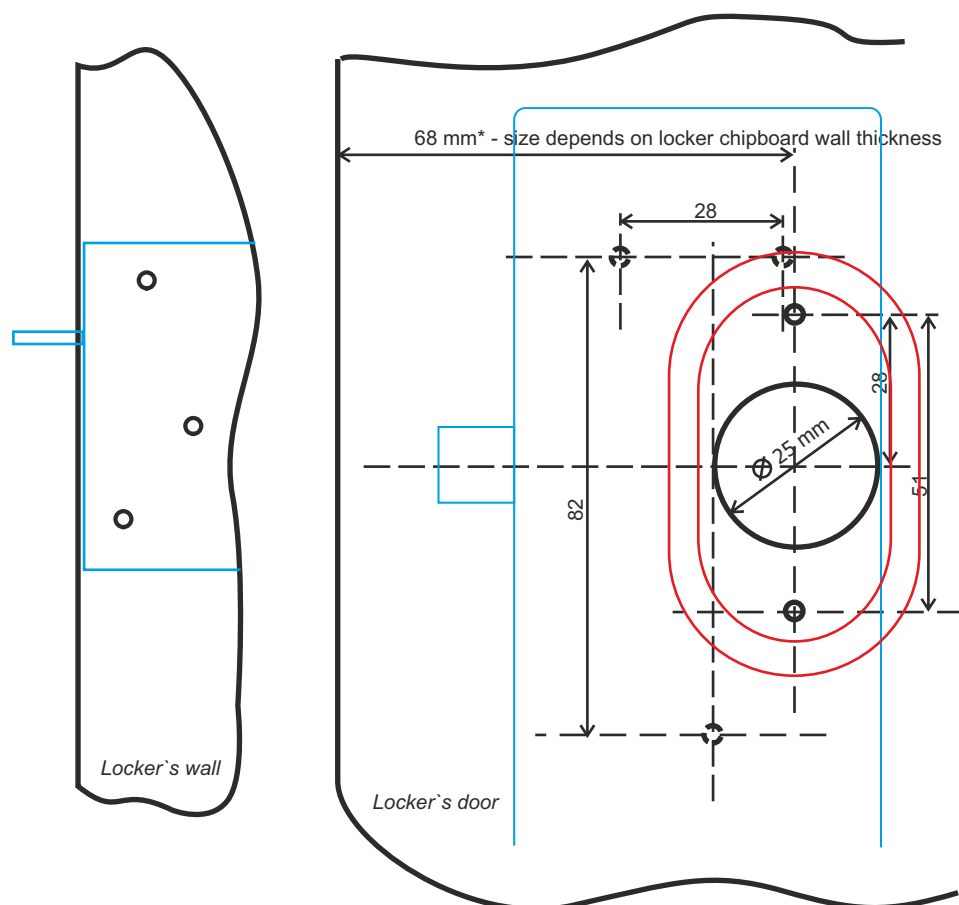

Fig.13

Holes Layout for Z-396 EHT installation onto a metal locker.

Important note! The size and design features of the doors of metal lockers usually varies from manufacturer to manufacturer. Please consult with us before installation.

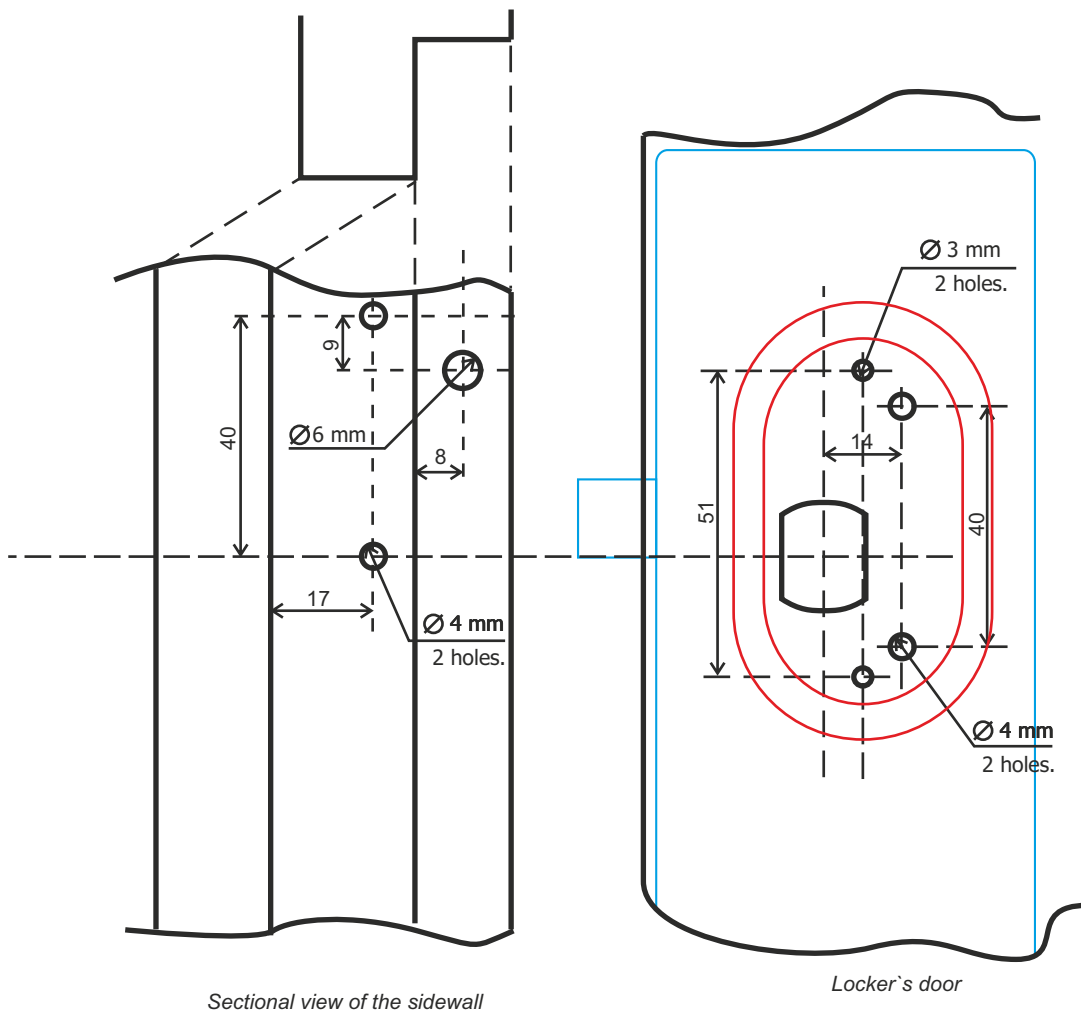

Fig.14