

# CP-Z 2MF-I Surface

## ACS RFID Mifare reader (13,56 MHz)

### User Manual

#### 1. OVERVIEW

CP-Z 2MF-I Surface RFID reader is used to read serial numbers of Mifare (ISO 14443-A) compliant tokens (cards, key fobs etc.), as well as to read and write the protected memory sectors of Mifare 1K, 4K and UltraLight compliant tokens.

#### 2. OPERATION MODES

##### 2.1. ACS RFID Reader.

The reader is connected to ACS controllers via iButton (Dallas Touch Memory), Wiegand-26 and Wiegand-34 protocols

2.1.1. Mode 1. The reader transmits UID (serial number) of all tokens.

2.1.2. Mode 2. The reader transmits UID (serial number) only of those tokens whose certain sector could be authorised (gained access).

2.1.3. Mode 3. The reader transmits the code from protected memory sector of Mifare tokens.

Mode 2 and Mode 3 setup is done via "M3NConf.zip" free software, found at <http://www.ironlogic.me>.

##### 2.2. Computer Reader.

The reader is connected and controlled by a PC, via RS-485 interface (through a converter).

2.2.1. Mode 4. The reader reads and writes protected memory sectors of Mifare tokens. To work with the reader in Mode 4, software libraries SDK Z-2 USB MF are required. <http://www.ironlogic.me>.

To configure Modes 2, 3 and to work in Mode 4, a Z-397 converter is required

<http://www.ironlogic.me>. The reader is connected via RS-485 point-to-point interface (NOT a network connection!)

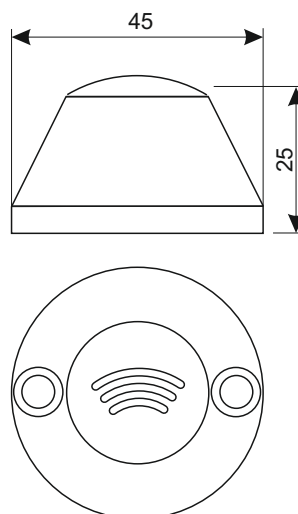

*Figure 1. Device dimensions.*

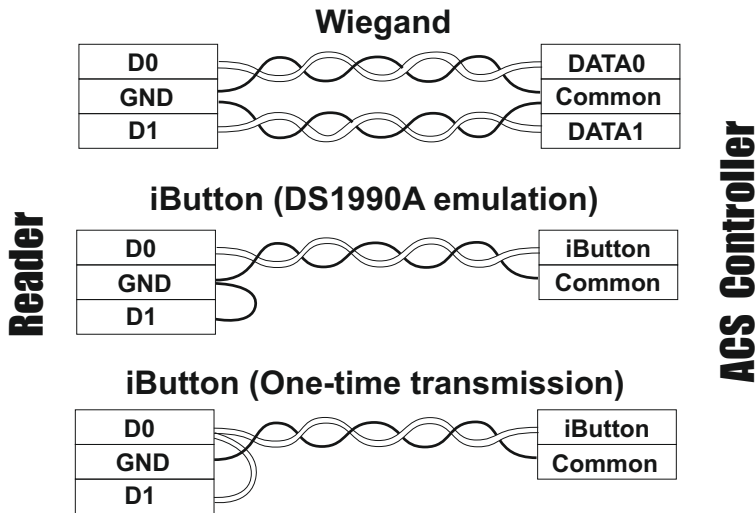

Figure 2. Choosing the transmission protocol.

red	+12V
black	GND
green	D0
white	D1
yellow	RED

Figure 3. The wires purpose.

### 3. MOUNTING AND CONNECTION.

The reader is mounted on a flat surface which allows to easily approach it with tokens. Please mount at ambient air temperature 5°C and above.

To mount the CP-Z 2MF-I Surface RFID reader, perform the following operations:

- Mark and drill mounting holes;
- Connect wires to the reader per Figures 2 and 3. When power is properly connected, the red LED will light up;
- To operate at the top of the specified line distance to controller, please use a UTP cable CAT5e;
- Insulate the wires junctions;
- Install the reader and tighten the holding screws.

### 4. READER OPERATION

When ready, the red LED is lit, indicating that reader is properly powered.

When a Mifare token is brought into reader working zone, its UID is read, and for Modes 2 and 3, also authorisation and reading additional codes from the token memory are performed. If the read operation was successful, it will be indicated by the LED shortly going dark.

At this moment the transmission occurs: in Modes 1 and 2, of the acquired UID, and in Mode 3 of the acquired protected memory sector. The data are transmitted to the controller via iButton (Dallas Touch Memory), Wiegand-26 or Wiegand-34 protocol. (as chosen during the configuration).

The configuration is performed by free M3NConf.zip software.

The reader has both internal and external indication control.

#### Internal Indication Control:

- The red LED is always on while no token is present in the reader working zone.
- On a token entering the working zone, the red LED is going off.
- While the token stays in the working zone, the red LED stays off.
- For Modes 2 and 3, when an uninitialized token is approached to the reader, the red LED momentarily turns off and then goes back on.
- While the uninitialized token stays in the working zone, the red LED stays on.

#### External Indication Control:

- Done by a controller via external control terminal RED, or RS-485 commands.
- Activated when an external control signal from the controller is detected.

Note: For Modes 2 and 3, when reading an uninitialized token, the red LED is momentarily going off and then back on.

**5. TECHNICAL SPECIFICATIONS**

Working Frequency: .....	13.56 MHz.
Tokens standard: .....	Mifare (1K, 4K, UltraLight).
Max. reading distance: .....	3 cm.
Ability to write into token memory: .....	Present.
Output Protocols: .....	iButton (Dallas Touch Memory), Wiegand-26, Wiegand-34, RS-485 (Emulation).
Max. reader to controller line distance:	
- via iButton protocol: .....	15 m.
- via Wiegand-26/-34 protocols: .....	100 m.
- via RS-485 protocol: .....	100 m.
Indication: .....	Visual.
External indication control: .....	Present.
Power supply voltage: .....	12 V DC
Standby operating current: .....	40 mA max.
Casing Material: .....	ABS Plastic with coating.
Dimensions, mm: .....	25x22.
Weight: .....	80 g max.

**6. OPERATIONAL CONDITIONS**

Ingress protection code: IP66.

Recommended air temperature: -30...40°C.

Humidity: ≤80% at 25°C.

If operational conditions are differing from described above, device specifications can deviate from specified values.

The controller is to be operated in absence of: precipitation, direct sunlight, sand, dust, water condensation.

**7. LIMITED WARRANTY**

This device is covered by a limited warranty for 24 months from the date of sale.

The warranty becomes void if:

- This Manual is not followed;
- Device has physical damage;
- Device has visible traces of exposure to moisture and aggressive chemicals;
- Device circuits have visible traces of being tampered with by unauthorised parties.

Under active warranty, the Manufacturer will repair the device or replace any broken parts, FREE of charge, if the fault is caused by manufacturing defect.

## 8. CONTACTS

### European & Global Wholesale Distribution Center

IRONLOGIC SIA

Spilves. 16, Riga, LV-1055 Latvia

<http://ironlogic.me>

[info@ironlogic.lv](mailto:info@ironlogic.lv)

Phone: +371 292 37870



The symbol of crossed-through waste bin on wheels means that the product must be disposed of at a separate collection point. This also applies to the product and all accessories marked with this symbol. Products labeled as such must not be disposed of with normal household waste, but should be taken to a collection point for recycling electrical and electronic equipment. Recycling helps to reduce the consumption of raw materials, thus protecting the environment.

