

Z-5R / Z-5R Case Controllers

User Manual

1. OVERVIEW

Controllers Z-5R or Z-5R Case (modification with plastic case) are used in Access Control Systems (ACS) as standalone controllers that operate electromagnetic and electromechanical locks, when connected to a Dallas Touch Memory contactor (reader for DS1990A keys), or a contactless proximity card reader emulating iButton (Dallas Touch Memory) protocol.

The following equipment can be connected to a Z-5R controller:

- External proximity card reader, transmitting information via iButton protocol, or Dallas Touch Memory contactor.
- Electromagnetic or electromechanical lock;
- Lock release button (normally unlocked);
- External LED;
- External buzzer;
- Door sensor.

2. SPECIFICATIONS

- External reader connection protocol:..... iButton (Dallas Touch Memory);
- Maximum number of keys:1364;
- DS1996L key support:Yes;
- Audiovisual indication:LED and buzzer;
- External control for LED and buzzer:Yes;
- Output for lock:MIS transistor;
- Switching current:5 A;
- Jumper for lock type selection:Yes, Electromechanical or electromagnetic positions;
- Lock release duration timer:0...220 s (factory default is 3 s);
- Power supply operating voltage:12 V DC;
- Maximum operating current:45 mA;
- Case dimensions, mm:65 x 65 x 20;
- PCB dimensions, mm:46 x 26 x 15;
- Case material (for Z-5R Case):ABS Plastic;

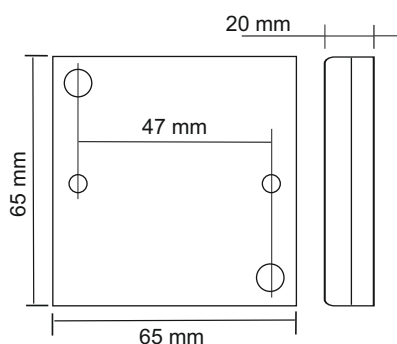

Figure 1: Controller case dimensions

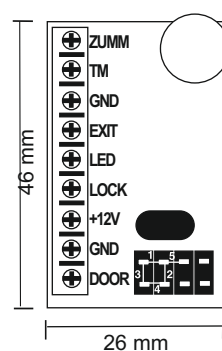

Figure 2: Controller PCB layout

Table 1. Terminals designation.

| No. | Terminal | Designation |
|-----|----------|---------------------------------------------------------------------------------------------------------------------------------------------------------------------------------------------------------------------------------------------------------------------------------------------------------------------------------------------------|
| 1 | ZUMM | External buzzer. Use a buzzer with a built-in generator for 12 V and consumption current not exceeding 50 mA. Buzzer's positive terminal is connected to +12 V terminal, and buzzer's negative one to this terminal. |
| 2 | TM | External reader or contactor. |
| 3 | GND | Signal ground, to connect "common" wires of an external reader, a contactor, a door sensor or a door release button. |
| 4 | EXIT | Door release button. Short-circuit it to release the door. A twisted pair (TP) connection recommended. |
| 5 | LED | External LED. Output current is limited to 20 mA, thus an LED can be connected without resistors. LED's positive terminal is connected here, and LED's negative one – to GND terminal. |
| 6 | LOCK | Terminal to connect the negative wire of a lock coil. |
| 7 | +12V | +12 V; to connect the positive terminal of a power supply, or the positive wire of a lock coil. |
| 8 | GND | Power ground, to connect the negative terminal of a power supply. |
| 9 | DOOR | Door sensor connects here. A twisted pair (TP) connection is recommended. The sensor is triggered by an open door. This allows to turn off the sound on the controller earlier, and to save the energy, by either turning off electromechanical lock after the door has opened, or turning on electromagnetic lock only when the door has closed. |

A twisted pair cable (e.g. UTP CAT5) should be used to connect the reader or key probe to the controller, to avoid interference.

When connected via iButton (Dallas Touch Memory) protocol, one wire of a twisted pair is used to connect GND terminals of the reader and the controller. Second wire of this twisted pair is used for signal transmission, and connects the reader output with the TM terminal on the controller (see Fig. 4 and 5).

The power to the reader can be delivered using a single wire. If unused wires remain in the cable, connect them between GND terminals on the reader and the controller.

3. OPERATING FEATURES

The Controller can work both with DS1990A keys, as well as contactless cards or tokens of various standards. To work with DS1990A keys, connect a contactor to controller. To work with cards, connect a reader supporting the corresponding card protocol (EM-Marine, Mifare etc.) The card readers should use iButton protocol to transmit codes to the controller, emulating DS1990A keys.

Because contactless systems have almost fully superseded contact ones in use, hereinafter we will describe the controller operation on example of a Matrix II reader connected via iButton (Dallas Touch Memory), which is almost 100% similar to operation with a contactor.

- ACS actions are determined from presence or absence of the card ID and card status in controller memory. "Card ID" is also often called a "key", so further in this document we shall consider "card" and "key" terms equal (e.g. we can say "touch with a card" or "touch with a key" with same effect). The full list of cards (keys) with their status, stored in controller's memory, is called ACS database.
 - To work with Z-5R controller, each new proximity card should be assigned a "status" (access rights). Status is determined during the card programming, on first approach of the card to the reader connected to the controller. Therefore, to change a card's status, delete it from the controller memory, then add it again with the correct status. Please note that to delete a Master card, the entire controller memory (ACS Database) must be erased or rewritten.
 - Card status can be as follows:
 - Master card is used for Z-5R programming only; never is used for access.
 - Normal (Access) card is used for passing through access point (except when in Blocking Mode).
 - Blocking card is used for both passing through access point (including when in Blocking Mode), and enabling/disabling the Blocking Mode.
- Note:** The Blocking cards open the lock when the card is taken away from the reader. A brand new Z-5R controller has empty memory. To operate a Z-5R, first store a Master card information into its memory. This Master card will be used for device programming. Later we will describe how to write a Master card.

ACS Operating Modes with Z-5R:

- Standard Mode access granted for both Normal and Blocking cards.
- Blocking Mode access granted only for Blocking cards, but not for Normal cards. Convenient when access needs to be temporarily restricted to certain group of people only.
- Accept Mode access is granted for existing Normal and Blocking cards, as well as any new cards. All new cards used in this mode will be stored into controller's memory, and assigned Normal card status. Thus after certain time spent operating in this mode, the controller will have built a new ACS database.
- Trigger Mode emulates a simple lock operation logic. Each card touch toggles the status of the power key, and hence, the lock status. Closing the power key issues one short beep, and opening it, four short beeps. This mode normally is used with electromagnetic locks, but other devices can also be used with it. However, please bear in mind that locking devices not designed for extended operating time, such as electromechanical locks, can fail when operating in this mode.

Simple one-door ACS solution variants:

A. Entry EM-Marine cards, Exit door release button:

- On entry: Matrix II reader.
- On exit: Door release button + power supply + (electromagnetic lock OR electromechanical lock/latch).

B. Entry and exit EM-Marine cards. The inside-room reader used for exit and the outside-room reader used for entry, are connected in parallel to the same terminal. The door release button is not required.

Audio-visual indication on the controller:

When the card touches the reader connected to the controller, it is either:

- Present in Z-5R controller database. The green LED blinks, the buzzer sounds, the lock is released for specified lock release duration (or until door sensor is triggered).
- Absent from Z-5R controller database. The green LED blinks twice, and two buzzer beeps are emitted.

4. PROGRAMMING

Important: Before programming the controller, please ensure that a contactor or an iButton-compatible (Dallas Touch Memory) reader is connected.

When describing programming procedures, we will use the term “card touch to the reader”. It means approaching the reader connected to this controller with a card, to a distance that will ensure reliable card ID acquisition (less than 2 cm).

Initial controller power-up (no keys in controller database yet).

Short beeps are sounding for 16 s, indicating that controller memory is empty and Add Master Key mode is active.

While the beeps are sounding, touch the reader with a card. This will store the card number as a Master card (Master key). The short beeps stop sounding, thus confirming successful creation of a first Master card.

To add more Master cards, keep touching them against the reader with intervals less than 16 s. Each touch will be confirmed by a short beep. The Add Master Card mode is exited automatically in 16 s after the last touch, confirmed by a series of four short beeps.

During subsequent operation, Master cards are used for programming.

If no cards were stored, repeat the initial power-up procedure. When the controller database is empty (i.e. no Normal, Blocking or Master cards exists), power-up will automatically activate Add Master Card mode.

If Master cards are lost, a new Master card can only be stored after erasing the entire controller memory, losing the existing database. It is however possible to backup and then restore the controller memory by using a Z-2 Base computer adapter and free BaseZ5R software (available at <http://www.ironlogic.me>).

Common facts about programming.

To put the controller into desired programming mode, use short (< 1 s) and long (~6 s) Master card touches of the reader connected to the controller. Programming mode has a time-out (~16 s) for any actions; when this period elapses, the controller will revert to normal operation mode, acknowledging with a series of four short beeps.

Mode 1. Add Normal and Blocking Card (1M)

Touch and hold (long touch) the reader with a Master key. On touch, the controller emits a short beep, acknowledging the Master card recognition, and in 6 s, one more signal, denoting activation of Add Normal and Blocking Cards mode. Take away the Master card now.

To add new cards, keep touching the reader with them, leaving no more than 16 s between touches. Each new card touch is acknowledged by a short beep, which confirms storing the card number into controller memory and sets the card status to Normal. If the card is still held at the reader for ~9 s more, a long beep sounds and the card status becomes Blocking. If the card is already present in controller memory, two short beeps will sound.

The Add Normal and Blocking Cards mode ends either automatically after 16 s after the last touch, or with a Master card touch. The controller confirms the exit with a series of four short beeps.

Mode 2. Add Master Cards (1m, 1M)

Touch the reader once with a Master card (short touch). On touch, the controller emits a short beep, acknowledging the Master card recognition. Within 6 s, touch and hold the Master card at the reader (long touch). On that touch, the controller emits two short beeps, acknowledging the second Master card touch, and in 6 s one more beep acknowledging that controller is now in Add Master Card mode. Take away the Master card now.

To add more Master cards, keep touching the reader with new cards, leaving no more than 16 s between the touches. The controller will confirm each new card touch by a short beep. If a card is already stored in memory as Master card, no signals are emitted.

The Add Master Cards mode ends automatically after 16 s after the last touch. The controller confirms the exit with a series of four short beeps.

Table 2. Programming Modes

| Modes | Activation | Legend |
|----------------------------------------------------------------|---------------------------|----------------------------------------------------------------------------------------------------------------------------------------------------------------------------------------------|
| Programming using Master keys | | 1...5 – # of touches |
| 1. Add Normal and Blocking Cards | 1M | * Uppercase letter – Long touch (hold key for ~6 s) * Lowercase letter – Short touch (hold key for <1 s) M – Master key N – Normal key B – Blocking key |
| 2. Add Master Cards | 1m, 1M | |
| 3. Erase Single Normal and Blocking Cards | 2m, 1M | |
| 4. Erase All Memory | 3m, 1M | |
| 5. Set Door Release Time | 4m | |
| 6. Blocking Mode | 1B | |
| 7. Accept Mode | 5m | |
| 8. Storing Controller Memory to DS1996L Key | 1m, 1M | |
| 9. Loading Information from DS1996L Key into Controller Memory | Initial power-up scenario | |
| Programming using Jumpers | | Do NOT set the jumper in any position not mentioned here: Risk of damaging the device! |
| 1. Electromechanical Lock | Position 1 | |
| 2. Erase All Memory | Position 2 | |
| 3. Add Normal Keys without Master Card | Position 3 | |
| 4. Electromagnetic Lock | Position 4 | |
| 5. Trigger Mode | Position 5 | |

Mode 3. Erase Single Normal and Blocking Cards with a Master Card (2m, 1M)

Touch the reader twice with a Master card (short touches). On first touch, the controller emits a short beep, acknowledging Master card recognition. On second touch, the controller emits two short beeps, acknowledging the second Master card touch in programming mode. Within 6 s, touch and hold the Master card at the reader (long touch). On third touch, the controller emits three short beeps, and after 6 s one more beep acknowledging that controller is now in Erase Single Cards mode. Take away the Master card now.

To erase Normal and Blocking cards, keep touching the reader with them, leaving no more than 16 s between the touches. Each condemned card touch is acknowledged by a short beep; if that card is not present in memory, by two short beeps.

The Erase Single Cards mode ends either automatically after 16 s after the last touch, or with a Master card touch. The controller confirms the exit with a series of four short beeps.

Mode 4. Erase All Memory with a Master Card (3m, 1M)

Touch the reader 3 times with a Master card (short touches). On first touch, the controller emits a short beep, acknowledging Master card recognition. On second touch, the controller emits two short beeps, acknowledging the second Master card touch in programming mode. On third touch, the controller emits three short beeps, acknowledging the third Master card touch. Within 6 s, touch and hold the Master card at the reader (long touch). On fourth touch, the controller emits four short beeps, and after 6 s a series of short beeps, acknowledging that controller memory has been erased and programming mode has ended. Take away the Master card now. On next power-up, the controller will automatically enter the programming mode.

Note: When the entire database is being erased with a Master card, the programmed Lock Release Time is not reset.

Mode 5. Lock Release Time Programming (4m)

Touch the reader 4 times with a Master card. On each touch, the controller emits beeps acknowledging Master card recognition; their quantity corresponds to the number of the touch. So on fourth touch, the controller emits four short beeps and enters the Lock Release Time Programming mode. Within 6 s from the last touch, press and hold the lock release button for the necessary time to keep the lock open. After the button is released, the controller emits a series of short beeps, stores the time to memory and exits programming mode.

Mode 6. Blocking Mode (1B)

In Blocking Mode, access is granted to Blocking cards only, and denied to Normal cards. Blocking Mode is set by Blocking cards (see Mode 1 for adding Blocking cards).

Blocking card is used:

- As a Normal card in normal operation (where access is granted to all Normal and Blocking cards stored in controller memory).
- To activate Blocking Mode (where access is only granted to Blocking cards).
- To deactivate Blocking Mode and revert to normal operation.

The controller opens the lock when the Blocking card is taken away from the reader.

To activate Blocking Mode on a controller, hold the Blocking card at the reader for ~3 s until a long continuous beep sounds, acknowledging activation of Blocking Mode. In this mode, attempting access via a Normal card fails, and a series of short beeps is emitted.

To leave Blocking Mode and go into normal operation, either 1) touch and hold a Blocking card near the reader (same sequence as Blocking Mode activation), until a series of short beeps sounds; or 2) touch the reader with a Master card quickly, until a series of short beeps sounds.

Note: If the supply power fails during Blocking Mode activated, it will stay active after the power is back on.

Mode 7. Accept Mode (5m).

Accept Mode is used to store all cards approaching the reader into controller memory, while assigning them Normal status. In this mode, a card approaching the reader opens the door and simultaneously gets stored into controller memory as Normal card. This mode is used to recover the user database without collecting the cards from the users. A Master card is required to activate this mode.

Touch the reader 5 times with a Master card. Each touch is accompanied by short beeps acknowledging the touch; the number of beeps equals the touch number. So on fifth touch, the controller emits five short beeps, then in 6 s, one more long beep, acknowledging activation of Accept Mode.

To leave Accept Mode, touch the reader with the Master card; a series of short beeps will acknowledge the mode exit.

Note: If the supply power fails during Accept Mode activated, it will stay active after the power is back on.

Mode 8. Storing Controller Memory into a DS1996L Key (1m, 1M)

To read the controller memory and store it into a DS1996L key, an iButton (Dallas Touch Memory) key contactor needs to be connected to the reader (see Fig. 5). Beforehand, the DS1996L key memory must be erased and initialised by BaseZ5R software.

Now activate Add Master Card mode, via a Master card. (See Mode 2 for description). For that, touch the reader with that Master card (short touch). On touch, the controller emits a short beep, acknowledging the Master card touch. Within 6 s, touch and hold the Master card at the reader (long touch). On this touch, the controller emits two short beeps, acknowledging second Master card touch, then a beep denoting the activation of Add Master Card mode on the controller. Now touch the contactor with DS1996L key and hold it until a series of short beeps sounds. That would copy all stored keys information (the database) from the controller into the DS1996L key. Now, using a Z-2 Computer Adapter (Z-2 Base or Z-2 EHR), it's possible to further copy this information from the DS1996L key into a computer.

Mode 9. Loading Information from a DS1996L Key into Controller Memory.

To load information from a DS1996L key into Z-5R controller memory, an iButton (Dallas Touch Memory) key contactor needs to be connected to the reader (see Fig. 5). The database must be already present in the DS1996L key, either previously read from controller memory, or loaded with BaseZ5R software. Beforehand, please erase controller's memory (either by a Master card or by a jumper). Then power cycle the controller (turn it off and back on). Initial power-up scenario will run. Touch and hold the DS1996L at the contactor. When information is copied from DS1996L into controller memory, a series of short beeps will sound. It takes no more than 25 s to copy the maximum number of keys (1364) into controller.

5. USING JUMPERS

One jumper comes with each Z-5R controller for programming. There are five valid jumper positions (see Fig. 3).

Position #1 Electromechanical lock selected (when the lock is closed, the voltage is off).

Position #2, CLR (Clear) to erase controller memory. For that, power off the controller, put the jumper into this position and power it on. When everything is erased, a series of short beeps is heard. All keys are erased and programmed door release timer is reset to factory default (3 s).

Position #3, ADD (Addition) to add Normal and Blocking cards into controller memory without using the Master card. For that, power off the controller, put the jumper into this position and power it back on. After a signal is emitted, the controller is in Add Normal and Blocking Cards Mode, without Master cards: a short touch adds a Normal card, and a long touch a Blocking card. After 16 s since the last card touch the controller leaves the Add Normal and Blocking Cards Mode (a series of short beeps is emitted).

Position #4 or No jumper Electromagnetic lock selected (when the lock is closed, the voltage is on). If no jumper is present, it has the same effect as if the jumper is installed in Position #4, i.e. electromagnetic lock is selected.

Important: Electromagnetic lock is unlocked only after any current has ceased in its coil, and the door release delay depends on how quickly the current fades down. To diminish this dependency, the controller is provided with the current choking circuit, which converts "extraneous" energy in its coil to heat, thus significantly reducing the lock release time. However, this circuit has limited abilities and if the access traffic is above 25 in 5 minutes, it can get overheated. To protect the current choking circuit for such access points, install a shunt diode in parallel to the lock coil. This, in turn, can increase the opening time for the electromagnetic lock by 1...3 s, compared to working current choking circuit. If such increase cannot be tolerated, install a varistor in sequence with the diode, with voltage ≤ 14 V and energy dissipation ≥ 0.7 Joule (such as V8ZA2P, see Fig. 6).

Position #5, Trigger Mode applicable for electromagnetic locks only: power off the controller, set the jumper into this position and power it on. In this mode, the controller can be in one of two positions: Closed (voltage supplied to the lock), and Open (no voltage supplied to the lock). To toggle between these positions, touch the reader with a Normal or Blocking card already present in controller memory (database).

The controller sound indication for position toggle:

- Open to Closed 1 short beep,
- Closed to Open 4 short beeps.

The managed lock should be connected to LOCK and +12V terminals.

Important: The whole jumper socket can be used to connect the controller to a PC via **Z-2 Base Computer Adapter** and with free **BaseZ5R** software (available for download at <http://www.ironlogic.me>).

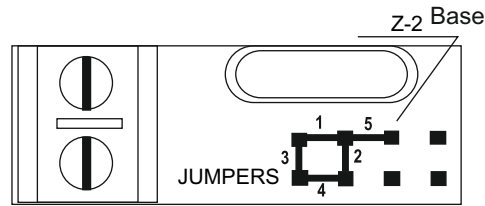

Figure 3. Jumper positions

6. MOUNTING AND CONNECTING

To mount a Z-5R Case controller, perform the following steps:

- Disassemble the case.
- Mark and drill the mounting holes for the case (as per Fig. 1)
- Connect the external devices to controller terminals according to the connection layout.
- Install the protective diode (see Fig. 6). If the lock is electromechanical, please set the jumper to position 1. (See Fig. 3).
- When the power is supplied, the controller will switch into programming mode (First power-up Writing Master cards see Chapter 4).
- Install the controller into case, put the and screw the lid onto the device.

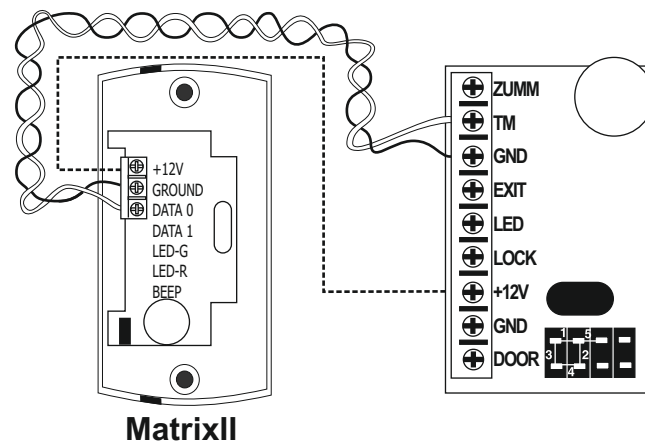

Figure 4. Connecting external reader.

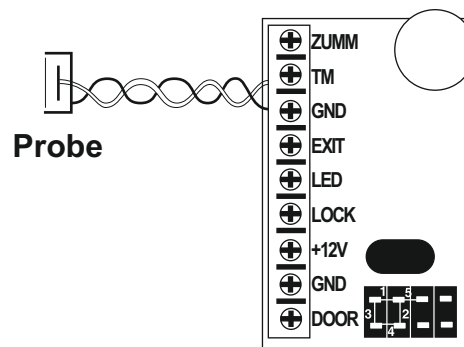

Figure 5. Connecting a probe.

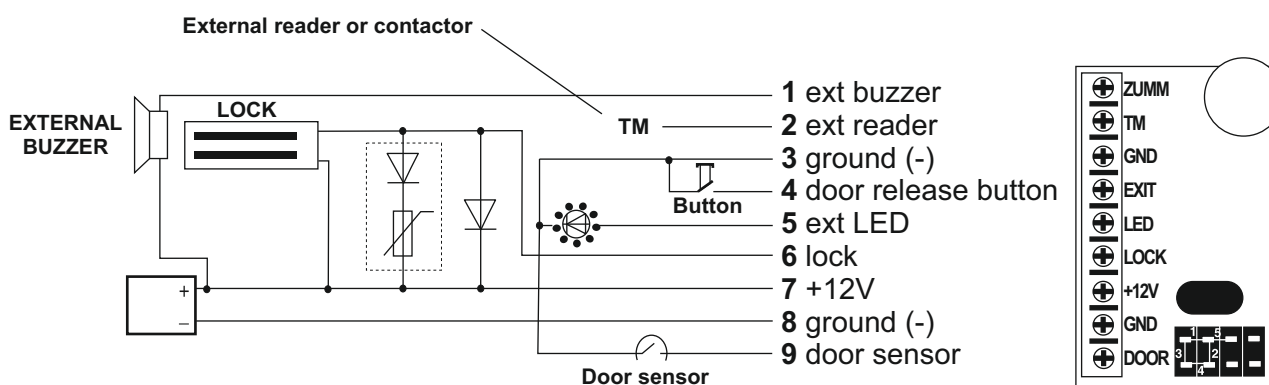

Figure 6. Connecting external devices.

7. PACKAGE CONTENTS

- Z-5R or Z-5R Case Controller: 1
- Jumper: 1
- Case (for Z-5R Case model only): 1

8. OPERATING CONDITIONS

Ambient temperature:-30...40°C.

Humidity:≤ 98% at 25°C

When operating under non-recommended conditions, device parameters can deviate from specified values.

The device must be operated in absence of: precipitation, direct sunlight, sand, dust, and moisture condensation.

9. LIMITED WARRANTY

This device is covered by a limited warranty for 24 months from the date of sale.

The warranty becomes void if:

- This Manual is not followed;
- Device has physical damage;
- Device has visible traces of exposure to moisture and aggressive chemicals;
- Device circuits have visible traces of being tampered with by unauthorised parties.

Under active warranty, the Manufacturer will repair the device or replace any broken parts, FREE of charge, if the fault is caused by manufacturing defect.

10. CONTACTS

European & Global Wholesale Distribution Center

IRONLOGIC SIA

Spilves. 16, Riga, LV-1055 Latvia

<http://ironlogic.me>

info@ironlogic.lv

Phone: +371 292 37870



The symbol of crossed-through waste bin on wheels means that the product must be disposed of at a separate collection point. This also applies to the product and all accessories marked with this symbol. Products labeled as such must not be disposed of with normal household waste, but should be taken to a collection point for recycling electrical and electronic equipment. Recycling helps to reduce the consumption of raw materials, thus protecting the environment.

